

Brake rectifier  
FWR



Brake rectifier  
HWR



Protective element  
PE-400/150/5



Switching rectifier  
SGL

Brake rectifier  
BGL+EGL

**PINTSCH BUBENZER**  
is certified according to  
DIN EN ISO 9001:2008



Reliable



High Performance



Robust



Easy Maintenance



Compact



Tried and Trusted

# Description Accessories



## Main Features

- EMC compatibility
- Top-hat rail mounted
- Combinable with Brake Control Unit BCU2001
- Integrated protective element
- Integrated spark quench element

## Specific Features for the rectifiers BGL and EGL

- Prepared for switching AC and DC circuits simultaneously
- Installation in cabinet

## Specific Features for the protective element PE 400/150/5

- To be connected parallel to the output of the rectifiers BGL, EGL and SGL to increase the interruption capacity

## Specific Features for the rectifiers FWR and HWR

- Prepared for switching AC and DC circuits simultaneously
- Installation in junction box

## Specific Features of the switching rectifier SGL

- Prepared for switching AC and DC circuits simultaneously
- Switches from bridge rectification to half-wave rectification
- Four time settings 0,5 s, 1 s, 1,5 s, 2 s adjustable
- Applying brakes at elevated temperatures
- Accelerated brake release (Overexcitation with AC power supply voltage = 2 x DC coil voltage)
- Accelerated brake effect (Standard excitation with AC power supply voltage = DC coil voltage)



### Please Note

We supply a detailed operating manual with every order. Nevertheless, we would point out that brakes are only as safe as the servicing and maintenance performed while they are in operation. The guarantee for the correct functioning of our brakes is only valid if the user adheres to the German DIN standard 15434 part 2 (drum and disc brakes, servicing and maintenance in operation), or to comparable standards in his own country.



### PINTSCH BUBENZER Service

This includes the verification of the brake selection, if required. A detailed questionnaire is provided for this purpose. Installation and commissioning on-site by PINTSCH BUBENZER service engineers is possible. Drawings as DWG/DXF files for your engineering department are available upon request.

# BGL-PE400/150/3 - EGL-PE400/150/5

Principal circuit diagram



Rev. 03-09

Bridge rectification with module BGL

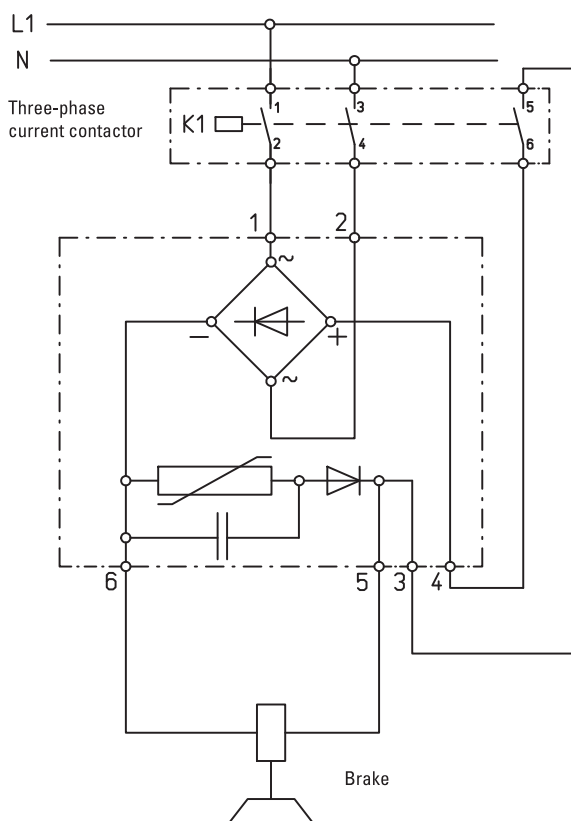

Half-wave rectification with module EGL

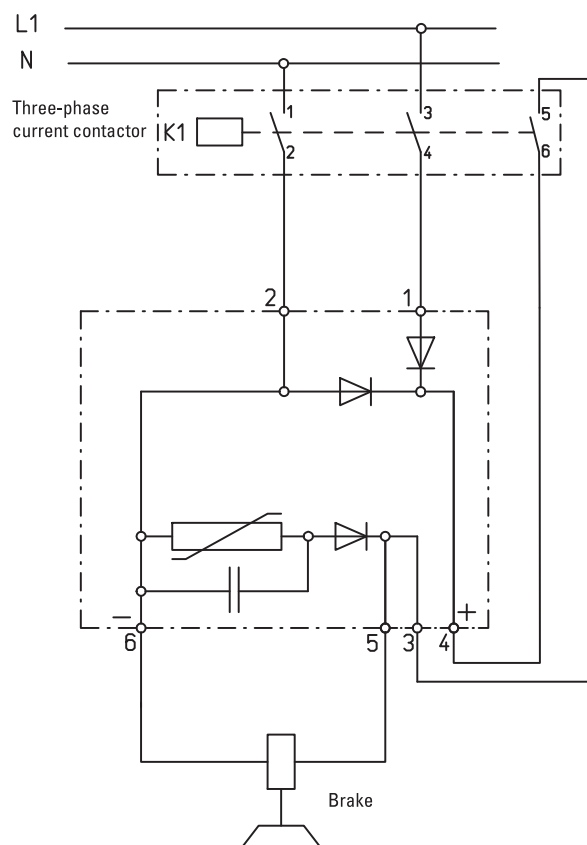

## Technical data

### Brake rectifier BGL-PE400/150/3

AC line voltage:	AC 460V; 50/60 Hz
Permissible rated coil voltages:	DC 24V...390V
Maximum brake current:	2,5A
Maximum continuous output of the internal protective circuit:	3W
Disconnection peak at maximum coil current:	≤450V
Ambient temperature:	-40° C ... +50° C
Protection class:	IP 20

### Brake rectifier EGL-PE400/150/5

AC line voltage:	AC 460V; 50/60 Hz
Permissible rated coil voltages:	DC 24V...220V
Maximum brake current:	5A
Maximum continuous output of the internal protective circuit:	5W
Disconnection peak at maximum coil current:	≤450V
Ambient temperature:	-40° C ... +50° C
Protection class:	IP 20

# Full wave rectifier FWR-PE400/150/3

Principal circuit diagram



Rev. 10-10

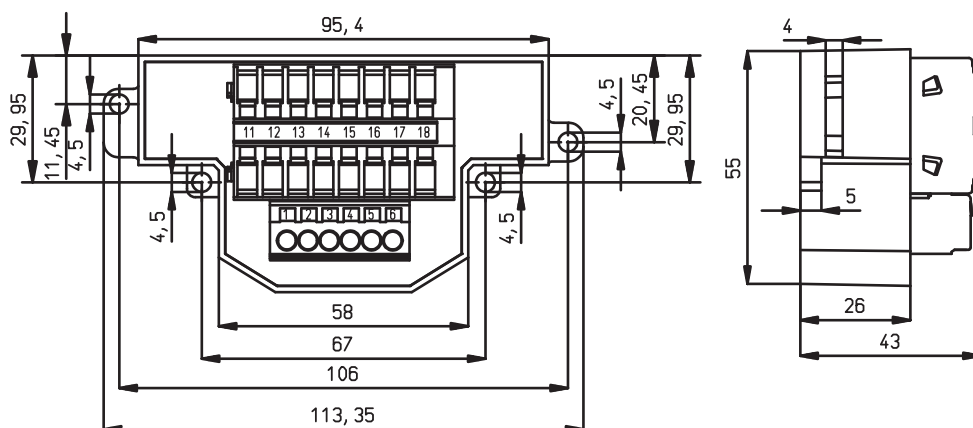
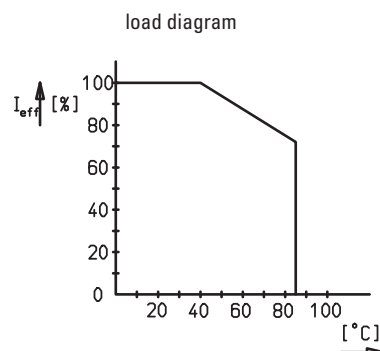
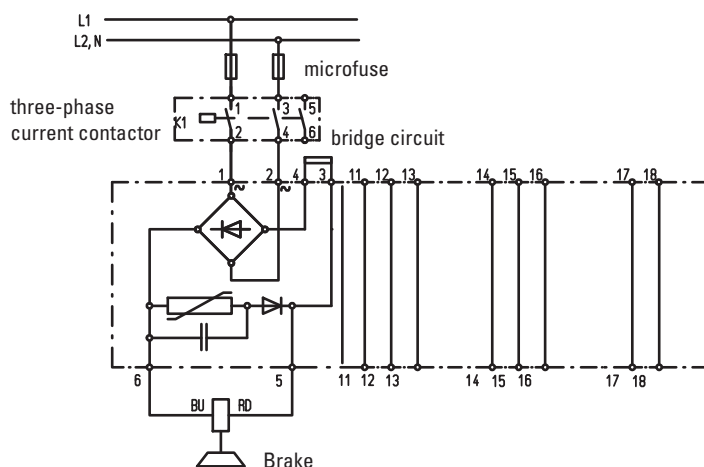

## Technical data

Coil voltage of the connected brake	DC 24V ... 390V
Max. voltage of supplying alternating current network	AC 460V - 50/60 Hz
Max. Output current $I_{eff}$ at $T_A = < 50^\circ\text{C}$	2,5 A
Max. Output current $I_{eff}$ at max. $T_A$ 85°C	1,8 A
Protection fuse in the AC input voltage line to the rectifier (In the selection of fuse is permissible on the $I^2 t$ limit load integral to eight)	FF 4A microfuse switching capacity H
Permitted limit integral $I^2 t$	700A <sup>2</sup> s (t < 10ms)
Max. energy absorption of a shut-off	150 J
Max. continuous power of the internal protective circuit (average value)	3W
Shut-off peak at max. coil current	< 450V
Ambiente temperature $T_A$	-40° C ... +85° C
Permissible cross section of connection wire	0,2 ... 2,5 mm AWG 24 ... 14
Weight	0,3 kg
Protection class	IP 65 components seal / IP20 terminals
Mark of conformity	CE / RoHS conform

# Full wave rectifier HWR-PE400/150/5

Principal circuit diagram



Rev. 10-10

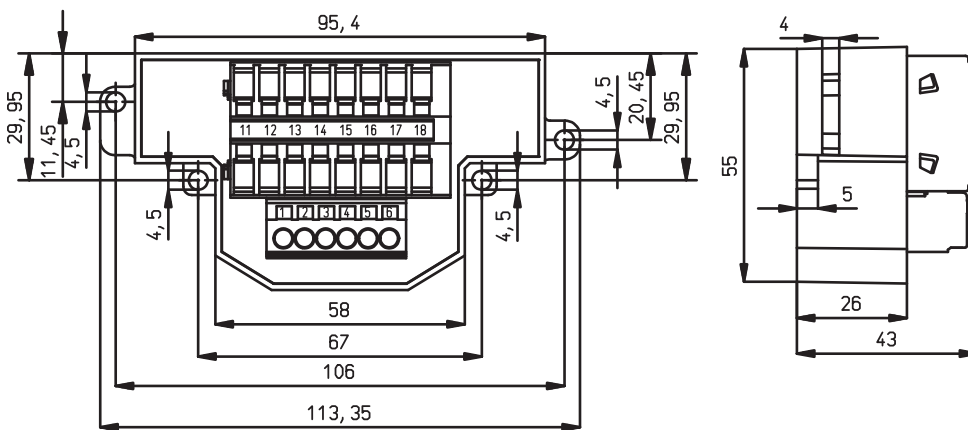
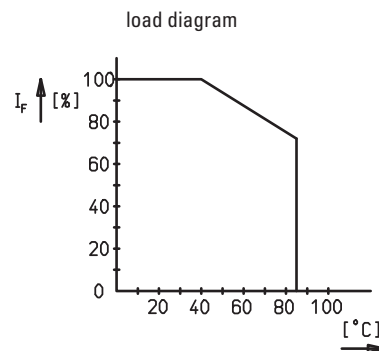
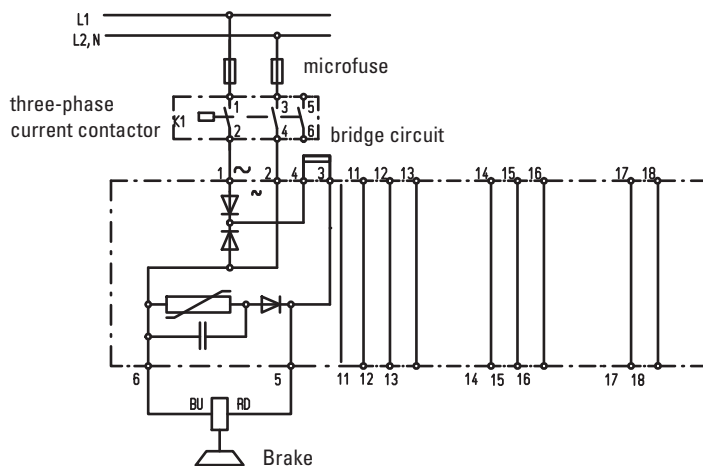

## Technical data

Coil voltage of the connected brake	DC 24V ... 240V
Max. voltage of supplying alternating current network	AC 550V - 50/60 Hz
Max. Output current $I_{eff}$ at $T_A = < 50^\circ\text{C}$	5 A
Max. Output current $I_{eff}$ at max. $T_A$ 85°C	3,6 A
Protection fuse in the AC input voltage line to the rectifier (In the selection of fuse is permissible on the $I^2 t$ limit load integral to eight)	FF 4A microfuse switching capacity H
Permitted limit integral $I^2 t$	700A <sup>2</sup> s (t <10ms)
Max. energy absorption of a shut-off	150 J
Max. continuous power of the internal protective circuit (average value)	5W
Shut-off peak at max. coil current	< 450V
Ambiente temperature $T_A$	-40° C ... +85° C
Permissible cross section of connection wire	0,2 ... 2,5 mm AWG 24 ... 14
Weight	0,3 kg
Protection class	IP 65 components seal / IP20 terminals
Mark of conformity	CE / RoHS conform

# Switching rectifier SGL

Principal circuit diagram



Rev. 03-09

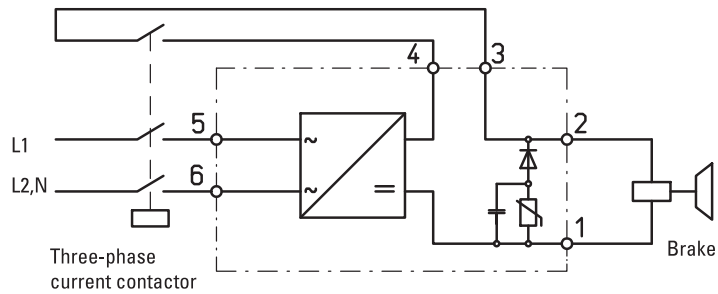

Switching rectification with module SGL

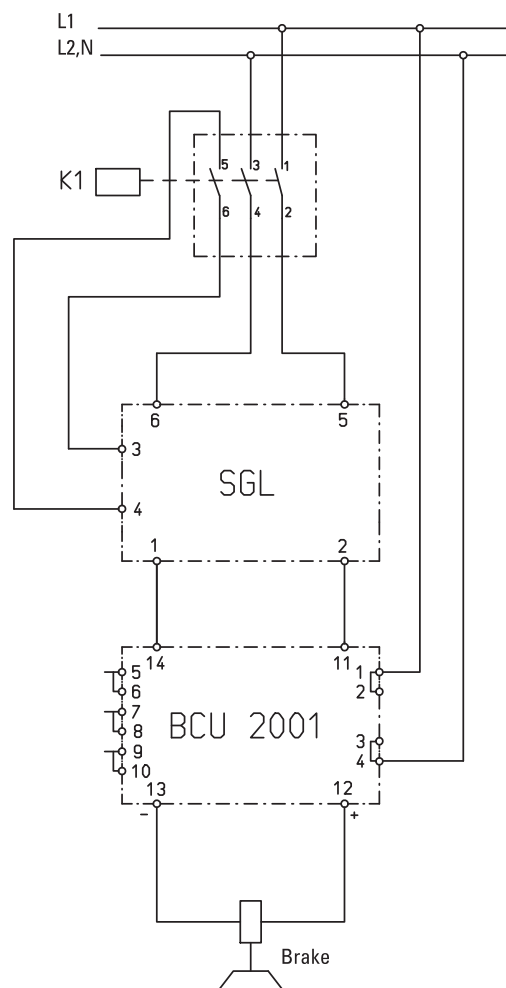

Switching rectification with module SGL combined with the Brake Control Unit BCU2001

## Technical data

AC line voltage:	AC 220V...484V; 50/60 Hz
Maximum brake current for 2 s:	8A
Maximum continuous output of the internal protective circuit:	5 W
Permanent brake current:	4A
Time settings by DIP switch:	0,5 s, 1 s, 1,5 s, 2,0 s
Ambient temperature:	-40° C ... +50° C
Protection class:	IP 20

# Protective element PE-400/150/5

Principal circuit diagram



Rev. 03-09

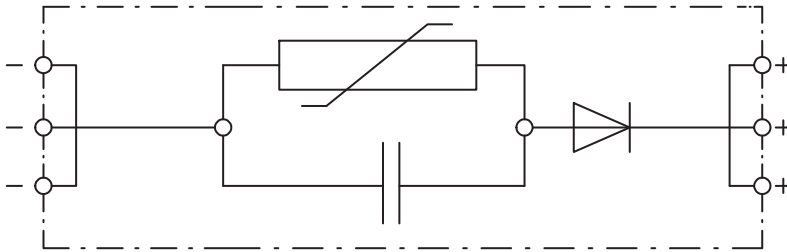

Protective element  
PE-400/150/5

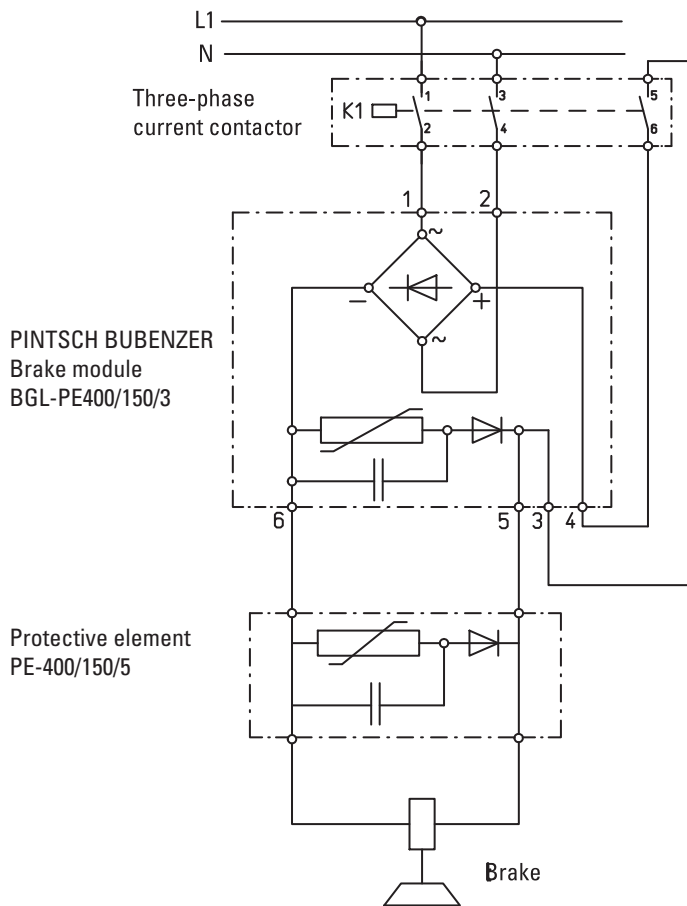

Bridge rectification with  
module BGL combined  
with the protective element  
PE-400/150/5

## Technical data

Maximum brake voltage:	DC 400V
Maximum brake current:	5A
Maximum continuous output of the internal protective circuit:	5W
Disconnection peak at maximum coil current:	≤ 450V
Ambient temperature:	-40° C ... +50° C
Protection class:	IP 20