

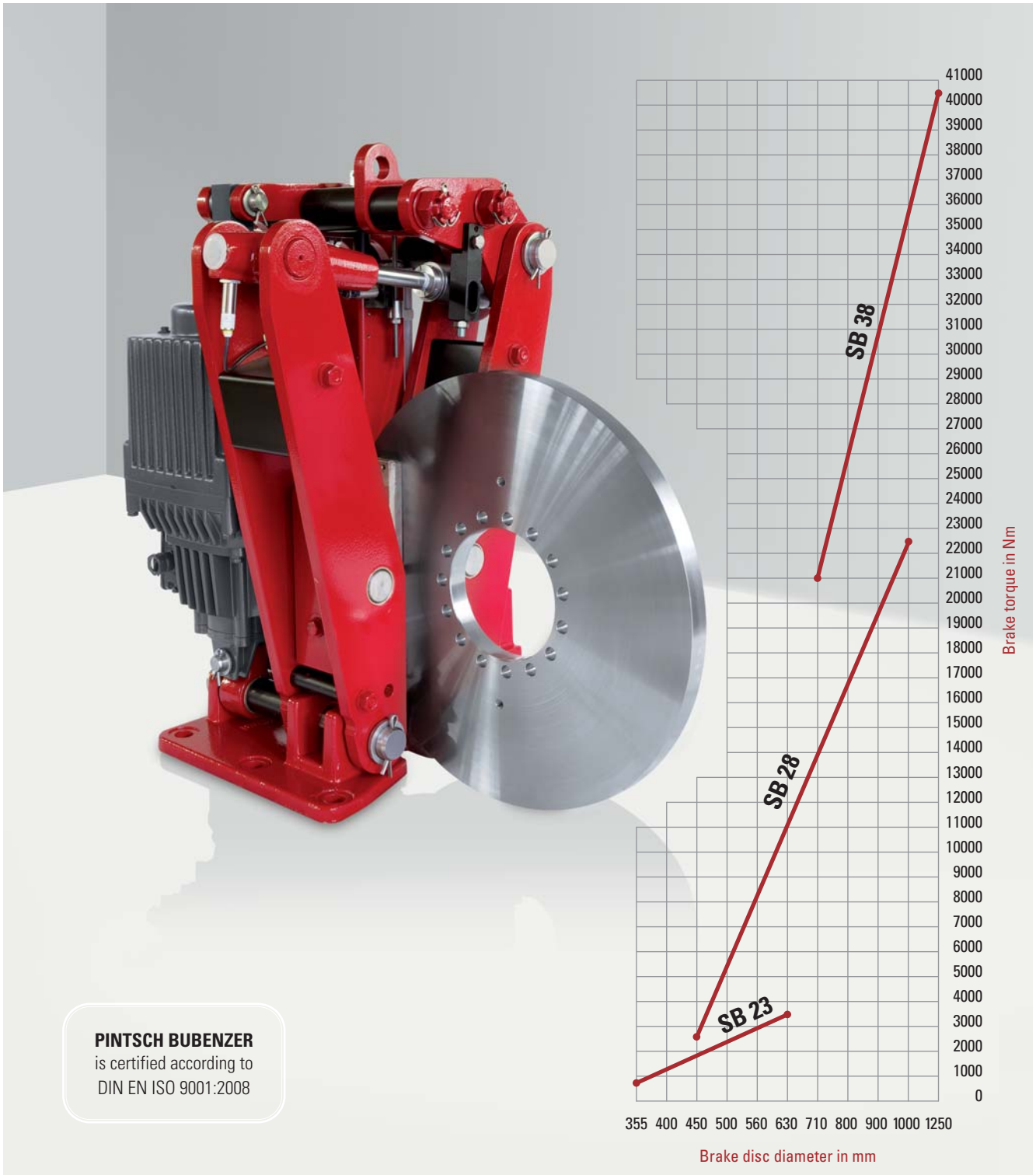





# Thruster Disc Brake SB 23/SB 28/SB 38



**PINTSCH BUBENZER**  
is certified according to  
DIN EN ISO 9001:2008

-   
**Reliable**
-   
**Self-Centering**
-   
**High Performance**
-   
**Robust Design**
-   
**Easy Maintenance**

# Description SB 23/SB 28/SB 38



## Main Features

- Patented self-centering of brake levers
- Automatic wear compensator
- Sintered linings for high friction speeds
- Continuously adjustable brake spring with torque scale and wear bushing enclosed in a spring tube
- Stainless steel pins and spindles
- Maintenance-free bushings in all hinge points
- Symmetric design
- W-execution (special anti-corrosion protection)

## Options

- Limit switch release control
- Limit switch wear control
- Limit switch manual release
- Manual release lever with or without lock
- Monitoring systems (e.g. VSR/CMB)
- Brake discs with hubs or couplings

## Ordering Example

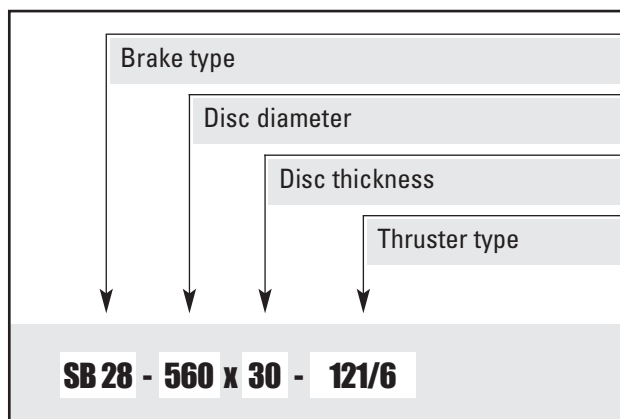

## Thrusters, Technical Data

Thruster Type	Power (W)	Curr. (A) at 400 V	Weight (kg)
Ed 50/6	210	0,5	23
Ed 80/6	330	1,2	24
Ed 80/7bb	330	1,2	27
Ed 121/6	330	1,2	39
Ed 201/6	450	1,3	39
Ed 301/6	550	1,4	40
Ed 301/10bb	550	1,4	40
Ed 501/8	900	1,8	42

Data supplied by thruster manufacturer, please take higher start current into consideration, fuses to be minimum 2A



### Please Note

We supply a detailed operating manual with every order. Nevertheless, we would point out that brakes are only as safe as the servicing and maintenance performed while they are in operation. The guarantee for the correct functioning of our brakes is only valid if the user adheres to the German DIN standard 15434 part 2 (drum and disc brakes, servicing and maintenance in operation), or to comparable standards in his own country.



### PINTSCH BUBENZER Service

This includes the verification of the brake selection, if required. A detailed questionnaire is provided for this purpose. Installation and commissioning on-site by PINTSCH BUBENZER service engineers is possible. Drawings as DWG/DXF files for your engineering department are available upon request.

# Disc Brake SB 23

Dimensions and technical data



Rev. 05-08

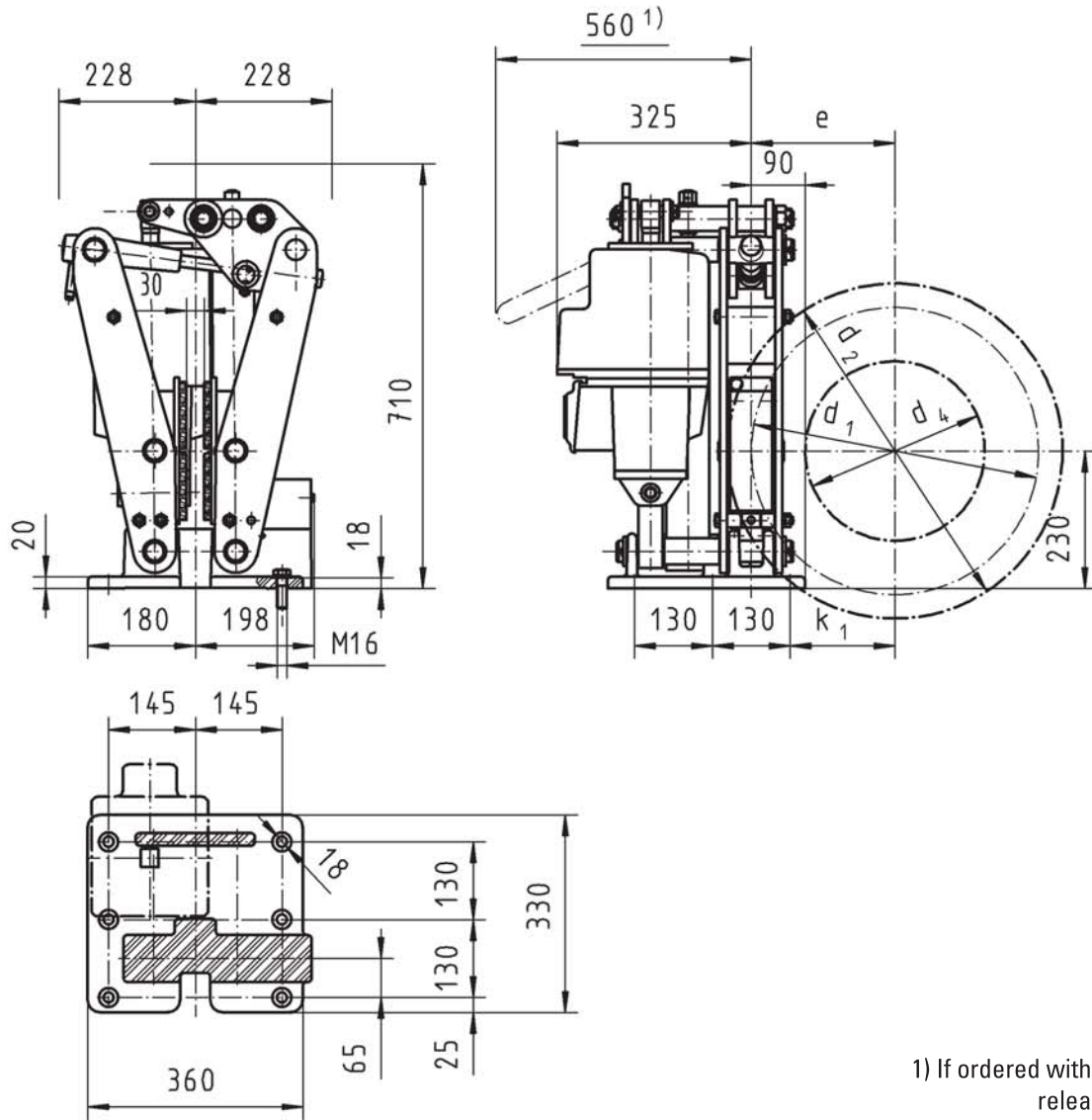

1) If ordered with manual release lever

\*) Average friction factor of standard material combination

For crane brake layout use safety factors documented in the FEM 1.001, Section 1

All dimensions in mm  
Alterations reserved without notice

Weight: 97 kg w/o thruster		Thruster type			Ed 50/6	Ed 80/6	Ed 80/7bb
		Contact force in N			8500	12500	16000
Disc Ø	Friction Ø				Brake torque M <sub>Br</sub> in Nm		Friction factor μ = 0,4*
d <sub>2</sub>	d <sub>1</sub>	d <sub>4</sub>	e	k <sub>1</sub>			
355	275	155	137,5	72,5	935		
400	320	200	160	95	1085	1600	2050
450	370	250	185	120	1255	1850	2370
500	420	300	210	145	1425	2100	2690
560	480	360	240	175	1630	2400	3070
630	550	430	275	210	1870	2750	3520

# Disc Brake SB 28

Dimensions and technical data



Rev. 10-08

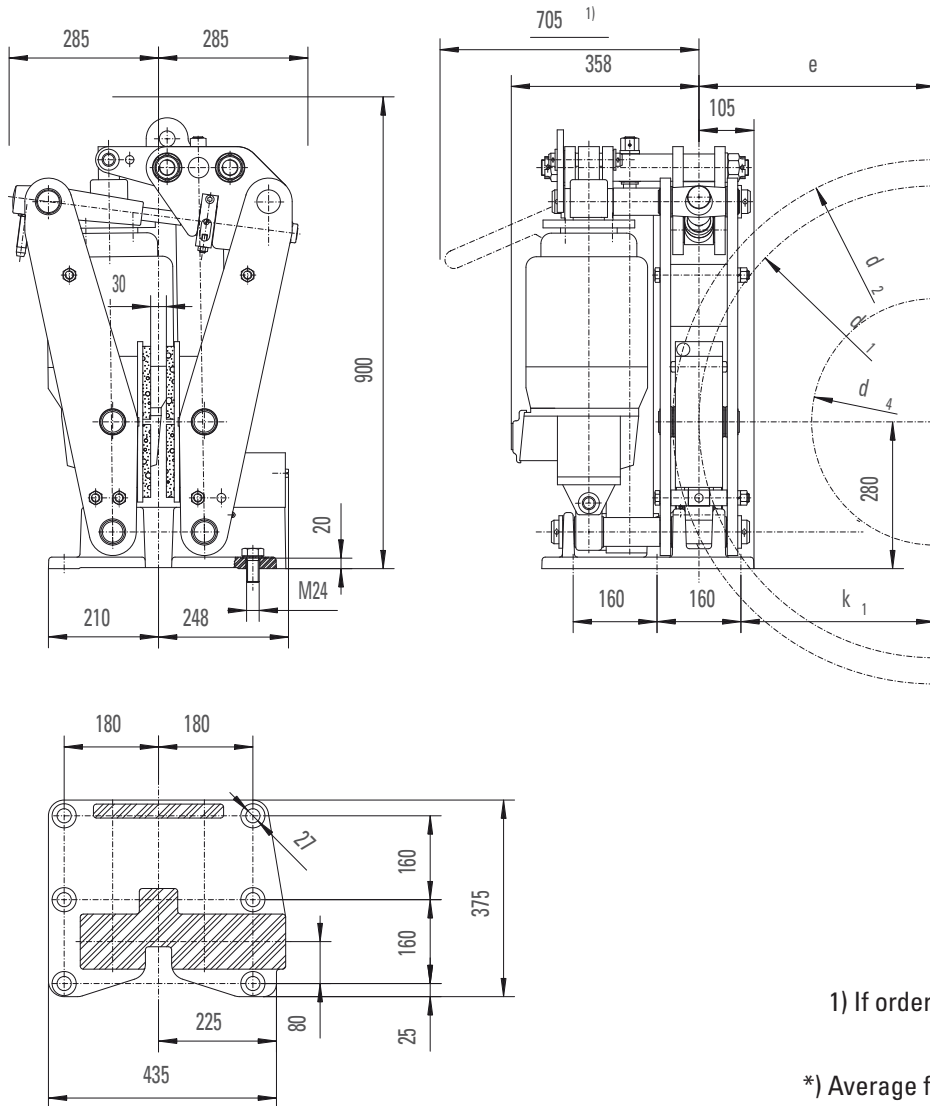

1) If ordered with manual release lever

\*) Average friction factor of standard material combination

For crane brake layout use safety factors documented in the FEM 1.001, Section 1

All dimensions in mm  
Alterations reserved without notice

Weight: 220 kg w/o thruster		Thruster type			Ed 121/6	Ed 201/6	Ed 301/6
		Contact force in N			19500	31500	46000
Disc Ø	Friction Ø				Brake torque M <sub>Br</sub> in Nm		Friction factor μ = 0,4*
d <sub>2</sub>	d <sub>1</sub>	d <sub>4</sub>	e	k <sub>1</sub>			
450	350	200	175	95	2700		
500	400	250	200	120	3100		
560	460	310	230	150	3550	5750	
630	530	380	265	185	4100	6600	9700
710	610	460	305	225	4700	7600	11200
800	700	550	350	270	5400	8800	12800
900	800	650	400	320			14700
1000	900	750	450	370			16500

# Disc Brake SB 28

Dimensions and technical data



Rev. 10-08

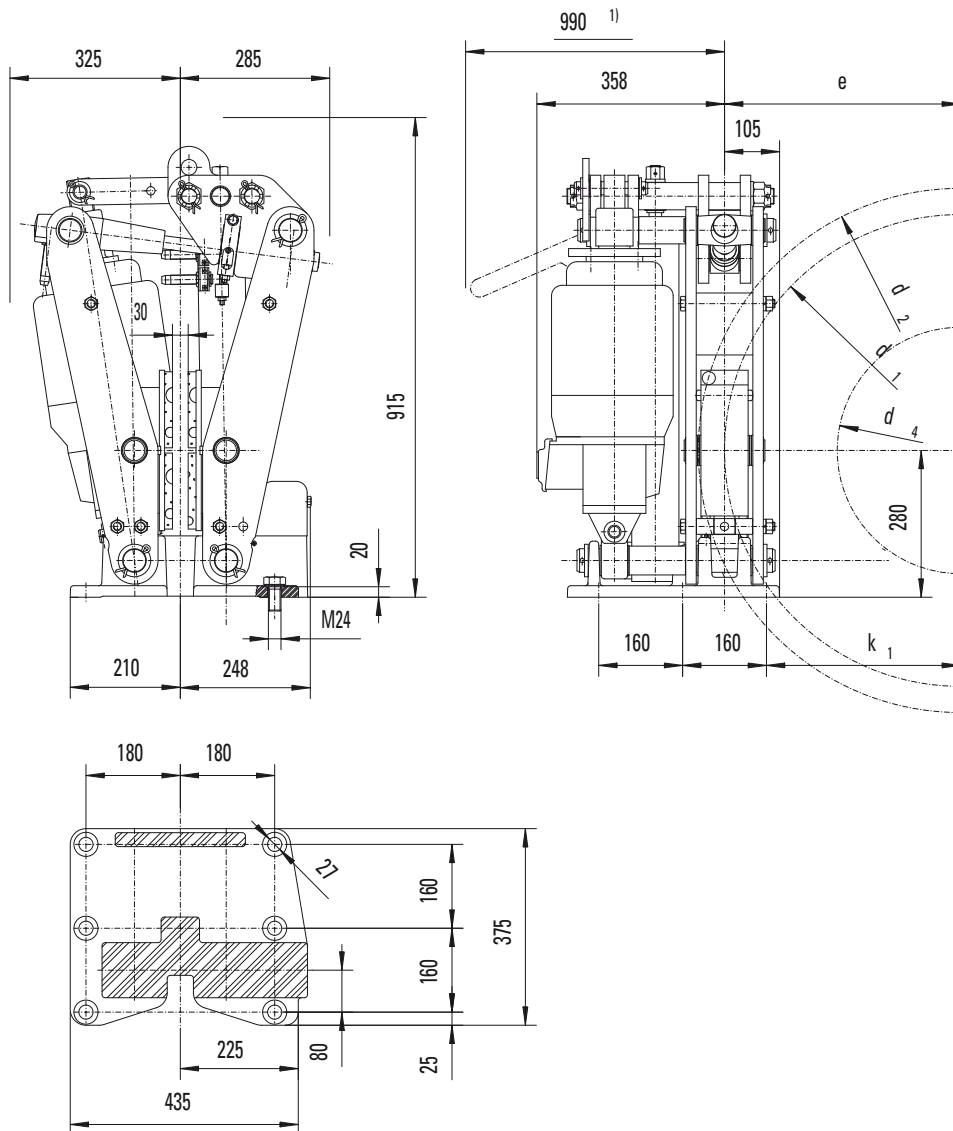

1) If ordered with manual release lever

\*) Average friction factor of standard material combination

For crane brake layout use safety factors documented in the FEM 1.001, Section 1

All dimensions in mm  
Alterations reserved without notice

Weight: 220 kg w/o thruster		Thruster type			Ed 301/10bb
		Contact force in N			62500
Disc Ø	Friction Ø				Brake torque $M_{Br}$ in Nm Friction factor $\mu = 0,4^*$
$d_2$	$d_1$	$d_4$	$e$	$k_1$	
710	610	460	305	225	15250
800	700	550	350	270	17500
900	800	650	400	320	20000
1000	900	750	450	370	22500

# Disc Brake SB 38

Dimensions and technical data



Rev. 12-06

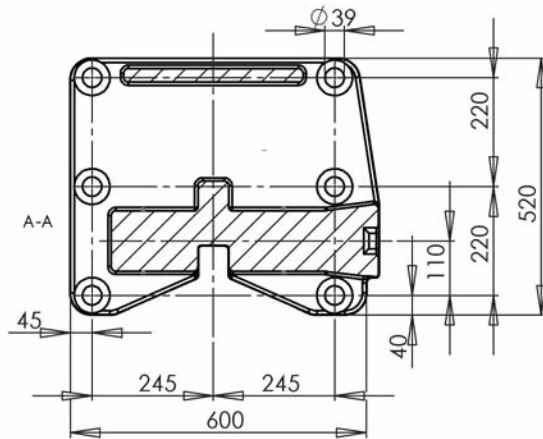
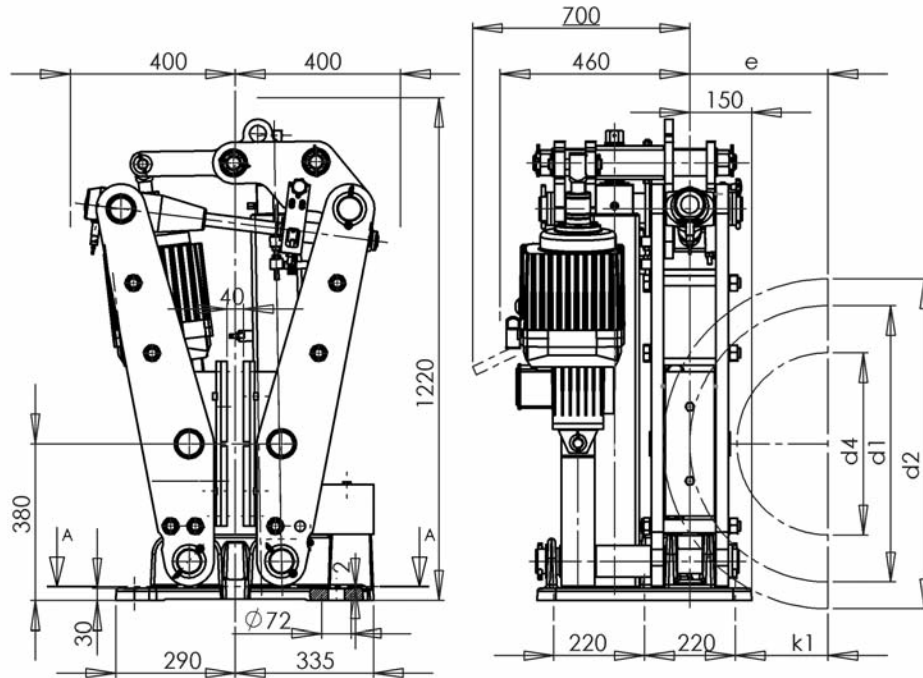

1) If ordered with manual release lever

\*) Average friction factor of standard material combination

For crane brake layout use safety factors documented in the FEM 1.001, Section 1

All dimensions in mm  
Alterations reserved without notice

Weight: 510 kg w/o thruster		Thruster type			Ed 501/8
		Contact force in N			91000
Disc Ø	Friction Ø				Brake torque $M_{Br}$ in Nm Friction factor $\mu = 0,4^*$
$d_2$	$d_1$	$d_4$	$e$	$k_1$	
710	580	350	290	180	21000
800	670	440	335	225	24500
900	770	540	385	275	28000
1000	870	640	435	325	31500
1250	1120	890	560	450	40500